

# **Thesis**

# **Project book**



**Project Title: GSM BASED THREE  
PHASE FAULT DETECTION AND  
PROTECTION SYSTEM**



# **UTTARA UNIVERSITY**

Department of Electrical & Electronic Engineering

**Project Title: GSM BASED THREE PHASE FAULT DETECTION  
AND PROTECTION SYSTEM.**

*Name of the Authors*

**Name: Al Mansur**

**ID : 2213171054**

**Name: Ali Hosen**

**ID : 2221171105**

**Name: Md. Rokibul Huda**

**ID : 2221171093**

**Name: Sharmin Akter**

**ID : 2221171094**

**Supervised by**

**Md. Shamsul Islam**

**Lecturer**

**Department of EEE**

In Partial Fulfillment of the Requirements for the Degree of  
BSc. in Electrical & Electronic Engineering

**December 2024**

# Declaration

We hereby declare that this thesis is based on the results found by ourselves. Materials of work found by other researchers are mentioned by reference. This thesis, neither in whole nor in part, has been previously submitted for any degree.

Signature of Supervisor

-----

Signature of Authors

-----

-----

-----

-----

# ACKNOWLEDGEMENT

First of all, we would like to give thanks to the almighty Allah. We would like to express our sincere gratitude to our honorable supervisor Lecturer **Md. Shamsul Islam, Lecturer Department of Electrical and Electronic Engineering, UU** who has always inspired us. Without his supportive advice and help, this project can not be completed. Thank you, for giving us the opportunity to choose this project. We also want to convey our thankfulness to **Head of the Department of EEE, UU** for his help, support and constant encouragement. We convey our humble heartfelt thanks to all the teachers of the Department of Electrical & Electronics Engineering, UU for their support in many ways throughout the work of this project. We are also grateful to the authors whose valuable research papers and books we have considered as a reference in this paper project.

We would also like to thank all our friends for sharing knowledge, data and helping us to make this project a success. Thank you also for supplying us with some tools and equipment. To our beloved family, during our studies at this University, we want to give them our deepest love and gratitude for being very helpful and for their inspiration and encouragement.

# ABSTRACT

The GSM based three-phase fault detection and protection system was designed to distinguish the type of fault that occurs in the power system, improved by the combination of Arduino, GSM Nodule and the current sensor. Any kind of electrical substation that provides electricity to users such as industrial or residential may have some faults that may be temporary or permanent. Nonetheless, due to problems such as the process, it takes longer to identify the form of fault and also involves manual reset of the fault to make the current protection system not effective in the supply of energy to the user. In this issue, we should build an outline to have a built-in intelligence to detect the incidence of transmission line error. A far-reaching monitoring and control system is developed to ensure a secure distribution operation and reduce the occurrence of accidents. This paper proposes Fault Detection, Send SMS, Identification and Auto Closed from Fault in Power Transmission Lines based on Arduino UNO, GSM Module, Current sensor and Relay hardware that helps to significantly reduce human effort reduces times and operates securely and skillfully without human interference.

# TABLE OF CONTENTS

<b>List of Figures</b>	<b>vii</b>
<b>List of Tables</b>	<b>viii</b>
<b>List of Abbreviations</b>	<b>ix</b>
<b>Acknowledgment</b>	<b>ii</b>
<b>Abstract</b>	<b>iii</b>
<b>Chapter 1: INTRODUCTION</b>	<b>10-12</b>
1.1 Introduction	10
1.2 Problem Statement	10
1.3 Objectives	11
1.4 Applications of this project	11
1.5 Literature Reviews	11
1.6 Research Methodology	12
1.7 Project Outline	12
<b>Chapter 2: LITERATURE REVIEW/BACKGROUND STUDY</b>	<b>13-27</b>
2.1 Introduction	13
2.2 Block diagram and how to work this project	13
2.3 Current Sensor	14
2.4 Over Current/ Over Load	14
2.5 Short circuit`	15
2.5.1 Type of short circuit fault	15
2.6 Project overview	15
2.7 System diagram	16
2.8 Component	16
2.8.1 Arduino UNO	17
2.8.2 Current Sensor	18
2.8.2.1 Pin configuration	19
2.8.2.2 Specification	19
2.8.3 Single channel Relay module	19
2.8.3.1 Output	20
2.8.3.2 Specifications	20
2.8.4 16×2 LCD Display	20
2.8.4.1 Features	21

2.8.4.2	Applications	21
2.8.5	Resistor	21
2.8.5.1	Resistor color band	22
2.8.6	Voltage sensor	22
2.8.7	Transformer	23
2.8.7.1	Features of 0-9V 300mA Transformer	23
2.8.7.2	Applications of 0-9V 300mA Transformer	23
2.8.8	Diode	23
2.8.9	Capacitor	24
2.8.10	Regulator	25
2.8.11	Male Female jumper wire	25
2.8.12	Adaptor	25
2.8.13	Toole needs	26
2..9	Summary	27

**Chapter 3: METHODOLOGY 28-31**

3.1	Introduction	28
3.2	Project Flowchart	28
3.3	Algorithm of the three phase detection device	29
3.4	Hardware connection picture	30
3.4.1	Description of hardware connection	30
3.5	Summary	31

**Chapter 4: RESULT AND DISCUSSION 32-37**

4.1	Introduction	32
4.2	Result	32
4.2.1	Generation Side	33
4.2.2	Distribution Side	34
4.3	Cost analyses	36
4.4	Advantage of the project	36
4.5	Summary	37

<b>Chapter 5:</b>	<b>CONCLUSION</b>	<b>38</b>
5.1	Conclusion	38
5.2	Limitation of the project	38
5.3	Future Scopes	38
	<b>References</b>	<b>39</b>
	<b>Appendix</b>	<b>40-48</b>

# LIST OF FIGURES

<b>Figure #</b>	<b>Figure Caption</b>	<b>Page #</b>
2.1	Block diagram of this project	13
2.2	Working principle of current sensor	14
2.3	System block diagram	16
2.4	Arduino UNO Board all pin section	17
2.5	ACS712 Current sensor module	19
2.6	Single module Relay	20
2.7	16×2 LCD Display	21
2.8.	Resistor	22
2.9	Transformer	23
2.10	Diode picture & symbol	24
2.11	Capacitor	24
2.12	Symbol of Capacitor	24
2.13	Electrical voltage regulator	25
2.14	Connecting wire	25
2.15	12V DC Adaptor	26
2.16	Needed tools	26
3.1	Flowchart of this project	28
3.2	Circuit diagram of this project	30
4.1	Final project	33
4.2	Normal condition (230V)	33
4.3	Low Voltage (Below 240V)	33
4.4	Higher Voltage (up to 345V)	34
4.5	Normal condition	34
4.6	Over load ( R phase)	34
4.7	Over load ( Y phase)	34
4.8	Over load ( B phase)	35
4.9	Phase unbalance YR	35
4.10	Phase unbalance BR	35

# LIST OF TABLES

<b>Table #</b>	<b>Table Caption</b>	<b>Page #</b>
2.1	Fault of Transmission line	15
2.2	Resistor color band table	22
4.1	Cost analysis of this project	36

# LIST OF ABBREVIATIONS

EB	Electricity Board
WNS	Wireless sensor network
SMS	Short Message Service
GSM	Global System for Mobile
AC	Alternating current
CT	Current Transformer
OCPD	Over current protection devices
NO	Normally Open
NC	Normally Closed
LCD	Liquid Crystal Device

# CHAPTER 1

## INTRODUCTION

### 1.1 Introduction

In recent months, electrical unexpected bad events have increased to the line man, while the electrical lines are repairing because the electrical substation and the maintenance team have no contact between them. Distribution system errors are much higher than transmission side losses, and distribution side failure is also more common. The survey shows that 80% of the service interruptions of the customer were attributed to distribution network failures. This plan offers a solution to this issue to ensure the safety of the lineman. For a safe operation of the power system, the identification and location of power line faults is very important. The command (ON / OFF) of the power lines rests with Line Man in this proposed system. The work is so organized that the electric power supply is ON / OFF by maintenance staff or line man. Now if there is a malfunction in electricity, the power supply is turned off and the electricity is fixed easily and, after the electricity supply to a specific line is switched on. [1] Special protection systems to improve accuracy and reliability by using contact schemes. There are several examples of fault over loading solid faults (i.e. unbalance load, Overload, Phase Failure Single line to ground, Double line to ground, Line to line, Triple line to ground, Three phase short circuit Faults), Overvoltage & Under voltage fault. The problem of error detection in the transmission line and the automated alert to Electricity Board (EB) is dealt with at the EB most errors detection and warning in the distribution line. The line man will then remove the power supply from the transmission line. This plan significantly reduces resources, saves time and runs effectively without human interference.

### 1.2 Problem Statement

In doing this project, we have encountered various problems such as voltage sensing problems, current sensing problems, right values, coding, problem with 1 Arduino and more. The project of detecting fault & defending will be unmatched even after specific obstacles. Even if it does, it will still have to upgrade the instrument and technology.

### **1.3 Objectives**

The ability of a transmission and distribution line can also be used for multiple purposes to protect and follow a sense object. To design a low-cost device for general purposes.

- I. To reduce the outage time due to faults and provide higher level of service continuity to the customers.
- II. To analyze how three-phase circuit faults could be recognized.
- III. To study how protected transmission and distribution line.
- IV. To help humans.
- V. To maintain system stability.
- VI. Disables the total system using an automated process.

### **1.4 Applications of this project**

- ❖ It can be use industry for the protected their machines.
- ❖ Use in Sub-station.
- ❖ Use in transmission and distribution line fault detection.
- ❖ Protected three phase induction motor.

### **1.5 Literature Review**

This review paper offers a comprehensive examination of the various types of faults that occur in inverters and the methods used for their identification. The introductory segment investigates the internal component failures of voltage-source inverters (VSIs), examining their failure rates and the consequent effects on the overall system performance. Subsequently, this paper classifies and clarifies the potential malfunctions in components and sensors, placing particular emphasis on their frequency of occurrence and the severity of their impact. The examination encompasses issues associated with transistors, including open circuits, short circuits, gate firing anomalies, as well as failures in capacitors, diodes, and sensors. Following this, the paper delivers a comparative assessment of fault diagnosis techniques pertinent to each type of component, appraised against specific criteria. The concluding section encapsulates the findings for each fault category, delineates the fault detection and diagnosis (FDD) methodologies, analyzes the outcomes, and provides recommendations for future scholarly investigation. In regard to the distribution system, the most essential part of the transmission lines is the transfer of power from the generating station to the load centers. In Bangladesh power system generating voltage 6.6kv/11kv/13.6kv, transmitting voltage 66kv/132kv/230kv/400kv but distributing voltage

11kv/400v/230v. Therefore, it's very important to the power system engineers have been objects for detecting and detecting faults since the development of the distribution and transmission system. [2]

## **1.6 Research Methodology**

Taking into account two things unique to this project, the approach was adopted. The project module is broken down into multiple sections. Each module is divided by itself. The current sensor, voltage measurement, high voltage failure, low voltage failure, overload defect, short circuit defect and unbalance fault identification are carried out step by step from the start of the voltage sensor. In this design, relays and sensors work easily. Fault identification is analyzed using these relays, GSM Module and sensors and an Arduino UNO is used to obtain three-phase circuit instructions based on the analysis obtained. It is a processor for transmitting digital signals and receiving analog signals. The object of this project is that if there is no damage to the circuit in case the relays flow because of failure (low voltage, high voltage, overload and unbalance) for any reason. And we put in place the foundation of the project after all the effort.

## **1.7 Project Outline**

This project is organized as follows:

In Chapter 1, we briefly discuss this project and the importance of this project in our daily lives.

In Chapter 2 we analyze our project with Block Diagram, Schematic Diagram and parts elements that we need to construct this project.

In Chapter 3, we will give a brief overview of all the hardware parts that we use in this project

In Chapter 4, we provide the result, output and advantage of our project.

In Chapter 5, we provide the consolation, disadvantage, future scope and some recommends.

# CHAPTER 2

## LITERATURE REVIEW/ BACKGROUND STUDY

### 2.1 Introduction

In this chapter we discussed various components that will be required to detect and protect three phase circuit faults.

### 2.2 Block diagram & How to work this project

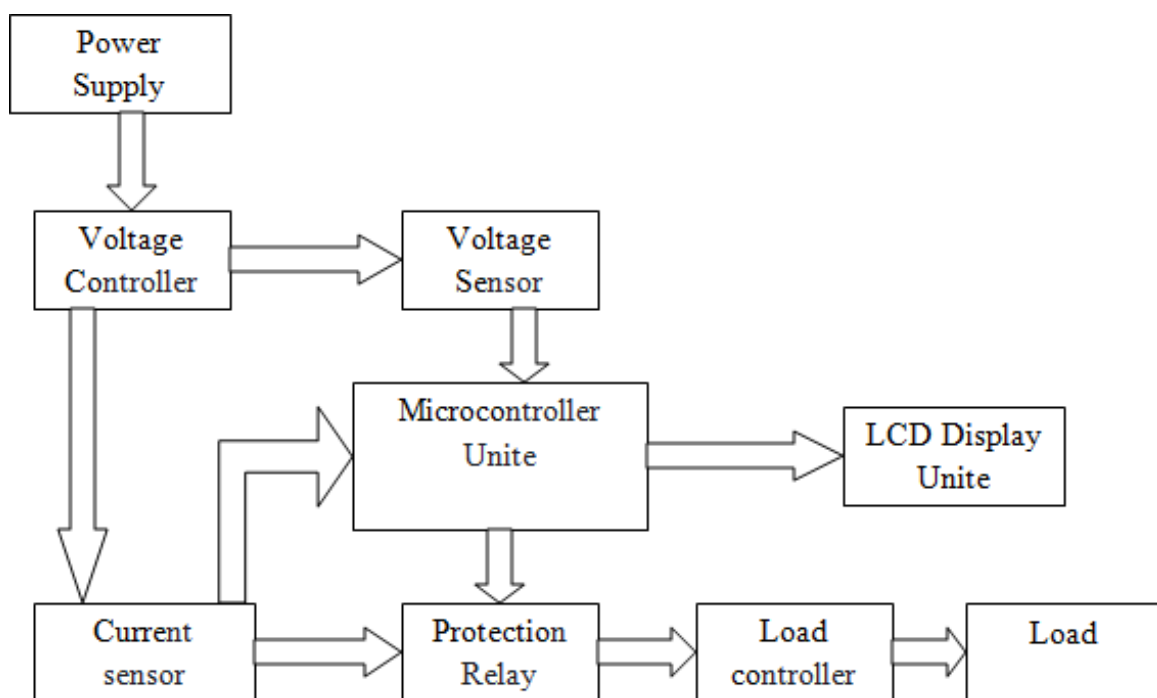

Fig. 2.1 Block diagram of this project

In this task, we measured the current using the current sensor. Before, let's assume we get line power on every device. The Arduino sends out a signal at the same time, the relay goes on, the voltage in the line starts flowing, the loads are moving. The current sensor checks the current on the line and provides Arduino with the analog signal which is provided in Adriano's digital language. The Arduino then shows the voltage on the display and senses the current sensor on the line by an additional 1 amp, and sends a signal to the Arduino relay and GSM Module. Now the relay and GSM Module receives the signal and tipping the relay and Send SMS By GSM Module so that the line has no problem and Notify to authority.

## 2.3 Current Sensor

AC (Alternating current) current will measurement used by the current sensor .In these part discusses about how to measure AC current using by the current transformer/CT.Current sensors measure the levels of AC and/or DC current. These sensors measure current and provide a kind of output that is consistent with the measured current. When choosing a current sensor, the most important point to make is whether AC and/or DC current must be measured. Another essential feature is if the sensor has to be attached to the circuit or if it operates by clamping the wire to be calculated. [15]

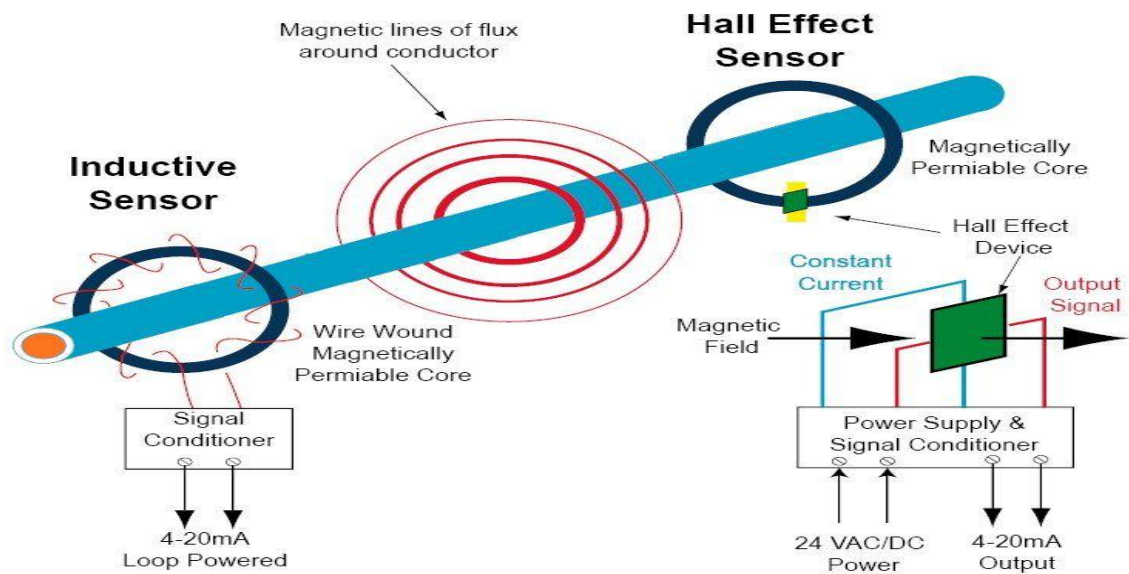

Fig. 2.2 Working principle of current sensor

## 2.4 Over current/Over load

Over current or large amounts of current in an electrical power system is a situation where there is a greater than intended electrical current through a conductor, resulting in excessive heat generation and the risk of fire or equipment damage. Over current causes include short circuits, excessive load, incorrect layout, or ground defect. For example, with an additional load, a 10-amp branch circuit is modified, the load current increases to 13 amps, this must be a circuit overload. Over current protection (OCP) controls are frequently used to control the risks by fuses, circuit breakers and current limiters. An over current may be caused by a circuit overload, a short circuit, a ground fault, or an arc fault. Circuit breakers and fuses protect the circuit from over damage. [4]

## 2.5 Short Circuit

A short circuit failure happens when an isolation failure occurs between phase conductors or between phase conductors and earth or both. An isolation failure results in the creation of a short circuit path that creates short circuit conditions in the circuit. [5]

### 2.5.1 Type of short circuit fault

- (i) Single conductor to earth fault (L-to-G)
- (ii) Conductor to conductor fault (L-to-L)
- (iii) Double conductor to earth fault (L-L-to G)
- (iv) Three conductor fault (L-L-L)

Table 2.1 Fault of Transmission line

Type of Fault	Symbol	%Occurrences	Severity
Line to Ground	L-G	75-80%	Very less severe
Line to Line	L-L	10-15%	Less severe
Double line to ground	L-L-G	5-10%	Severe
Three phase	L-L-L	2-5%	Very severe

## 2.6 Project Overview

This project, a short circuit kept from a dangerous situation, gives us excessive overload. We mean how to use all devices from the dangerous effects during the transit to the government. Over current protection devices (OCPD) are intended to protect against the potentially harmful impacts of over currents, such as overload current or short-circuit current, which creates a current of failure. Damage to machinery, personal injury, and even death may result from incorrect use of the voltage rating, current rating, or malfunction rating of a system. Something as simple as a circuit breaker will defend against such harm, but if a fuse or circuit breaker does not have an appropriate voltage rating, it can break or burst when trying to stop fault currents beyond their disrupting ratings. Grounding defends against inadequate over current or failure of the OCPD. These systems are structured for the safety of machinery, assets and individuals. [10]

## 2.7 System Diagram

The system block diagram in shows as,

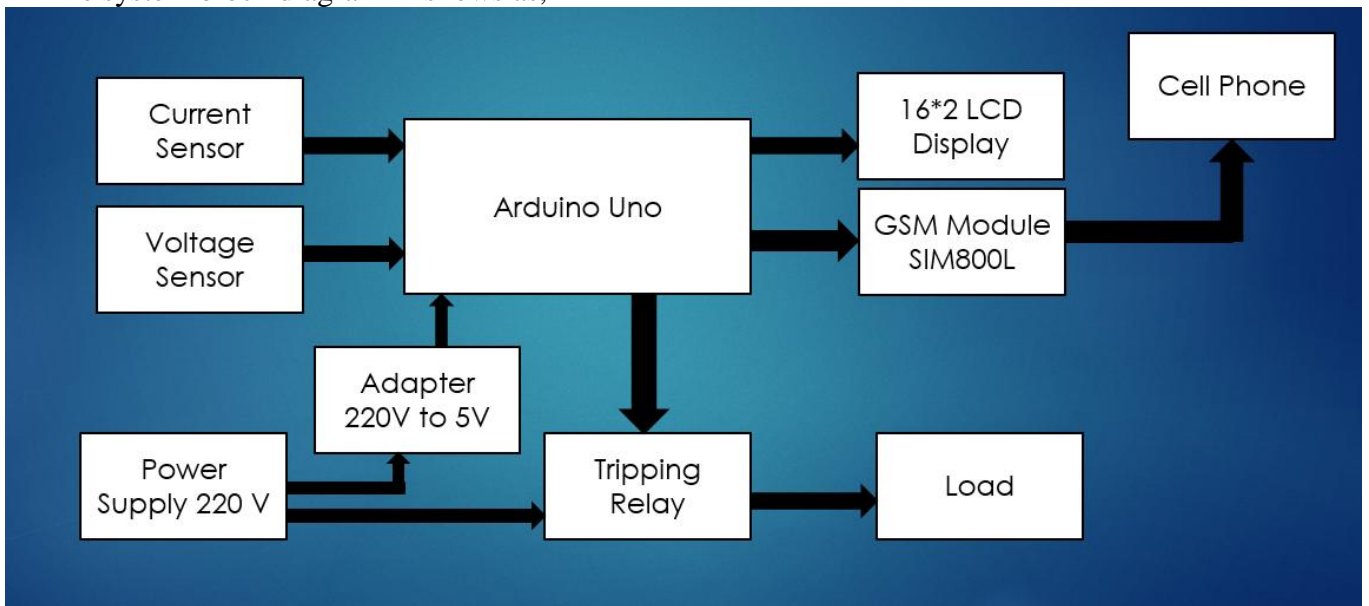

Fig. 2.3 System block diagram

## 2.8 Component

Three phase fault detection and protection has the following components:

1. Arduino Uno
2. Current sensor
3. Single channel relay module
4. 16x2 LCD
5. Resistor
6. Voltage sensor
7. Transformer
8. Diode
9. Capacitor
10. Regulator
11. Wire
12. Adaptor
13. Tools needed

## 2.8.1 Arduino Uno

The Arduino Uno is an open source microcontroller board based on the Arduino ATmega328P microcontroller. It has 14 digital input /output pins & 6 analog input/output pins, a 16MHz crystal oscillator, a USB connection, co jack that works with 5 volt, an ICSP header, and a reset button jack that works with 5 volt, an ICSP header, and a reset button a power jack that works with 5 volt, an ICSP header, and a reset button. It's programmable with the Arduino IDE (Integrated Development Environment), via a type B USB cable.

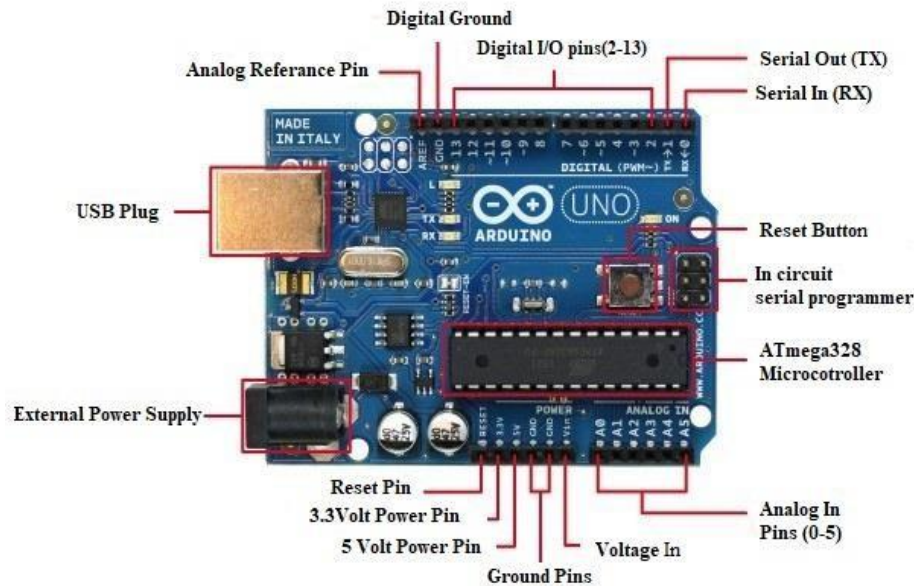

Fig. 2.4 Arduino UNO board all pin section

Here we discuss about the function of the Arduino Board element.

1. **USB Plug:** The Arduino board can be powered by a USB cable from y computer. It also use for uploading program.
2. **Power Supply:** Arduino boards could be directly connected to the Barrel Jack from the AC mains power supply.
3. **Voltage regulator:** In this function control voltage given voltage Arduino board.
4. **Arduino Reset:** We can reset our board of Arduino; begin our program from the start. There are two ways we can reset the board of UNO. Next, to use the board's reset button (17). Second, we can attach an external reset button to the RESET named Arduino pin (5).
5. **Pin(3.3, 5V, GND, Vin) :**
  - 3.3V (6): Supply 3.3V output side.
  - 5V (7): Supply 5 V output side.

**GND (8):** The Arduino has several GND pins that can be used to ground our circuit.

**Vin (9):** This pin can also be used as a power source for Arduino's board such as AC power source.

6. **Analog pin:** The Arduino UNO has six analog pins A0 through A6. This pin also read the analog signal from the analog sensor.
7. **Main microcontroller:** Arduino board has its own microcontroller (11), which can be considered to be the board's brain. Arduino's central IC (integrated circuit) differs significantly from board to board.
8. **IC SP Pin:** ICSP (12) is mostly an AVR, a tiny Arduino program header made up of MOSI, MISO, SCK, RESET, VCC and GND.
9. **Power LED indicator:** When we connect our Arduino into a power source to show that your panel is properly powered up, this LED will light up.
10. **TX and RX LEDs:** There are two labels on your board: TX (transmit) and RX (receive). They appear on the Arduino UNO board in two places. First, to indicate the pins responsible for serial communication at the digital pins 0 and 1. Second, the leadership of TX and RX (13).
11. **Digital I/O:** The board of Arduino UNO has 14 digital I / O pins (15) 6 of which provide output of PWM (Pulse Width Modulation).
12. **AREF:** AREF is an analog reference. This is sometimes used as the upper limit for analog input pins to set an existing reference voltage (between 0 and 5 Volts).

## 2.8.2 Current Sensor

A current sensor is a system which identifies and produces a signal that is proportional to that current in a cable. The voltage fall happens when a current passes through a wire or in a circuit also, the current carrying conductor is surrounded by a magnetic field. Both of these phenomena are used in modern sensor development. The created signal can be analog voltage or current or even digital output. A calculated current in an ammeter can be reflected by the produced signal, or can be processed in a data capture device for further evaluation or for controlling purposes.

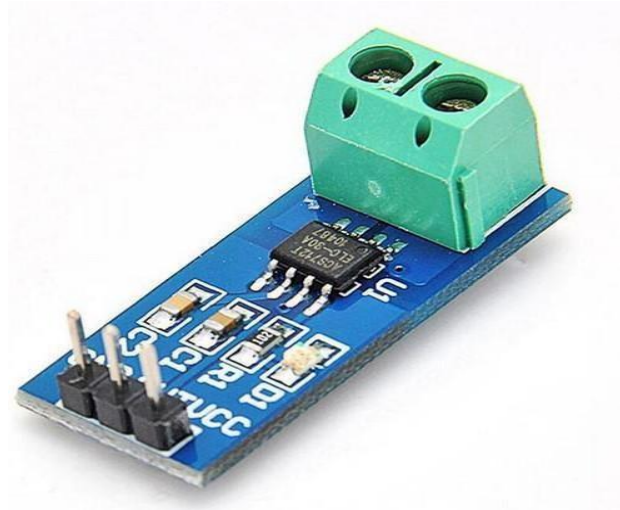

Fig. 2.5 ACS712 Current Sensor

### 2.8.2.1 Pin configuration

- (i) **VCC:** Input voltage is +5V for typical applications.
- (ii) **Output:** Outputs Analog voltage proportional to current.
- (iii) **Ground:** Connected to ground of circuit
- (iv) **Wire In:** The wire through current has to be measured is connected here AC 220 volt supply.
- (v) **Wire Out:** It power supplies the series AC with the sensor output and receives 220 volts

### 2.8.2.2 Specification

- (i) Measures both AC and DC current.
- (ii) Available as unit 5A, 20A and 30A.
- (iii) Provides load isolation.
- (iv) Easily integrated with MCU, since the analog voltage variable is output.

### 2.8.3 Single channel relay module

It is a LOW Level 5V single-channel relay control panel and the channel requires 15-20mA for operate circuit Can be used for monitoring different big current appliances and equipment. The AC 250V 10A is fitted with high-current relays. It has a standard functionality, which can be directly controlled by a microcontroller.



Fig. 2.6 Single Module Relay

### 2.8.3.1 Output

It is well known that 3 pins, like NO, NC, COM are available for the output of the relay module. One is normally going to be close and one is going to be in the common mood. But there are two pin contact shorts between NC and COM. So we can understand how to toggle relays. We use the 1-channel relay unit, 1 NC, 1 COM and 1 NO connection.

### 2.8.3.2 Specifications

The 1-channel relay unit specifications are as follows.

- (i) Secure good. The lower current can be regulated by the higher power system and high voltage device
- (ii) 1-channel high-voltage output unit to satisfy single-channel power criteria.
- (iii) Large range of voltage controlled.
- (iv) Capable of regulating high current of 240V, 10A.
- (v) A contact normally open (NO) and a contact normally closed (NC). [6]

## 2.8.4 16×2 LCD Display

All around us we consider Led screens. The use of some kind of time display is done by computers, calculators, TV sets, mobile phones and digital watches. An LCD is an electronic display device that produces a visible image using fluid crystal. The 16×2 LCD display is a very simple unit that is widely used in DIYs and circuits. The sixteen to two is translated in two of these lines into sixteen characters per line. Every character in this LCD is shown in a matrix of 5 pixels.

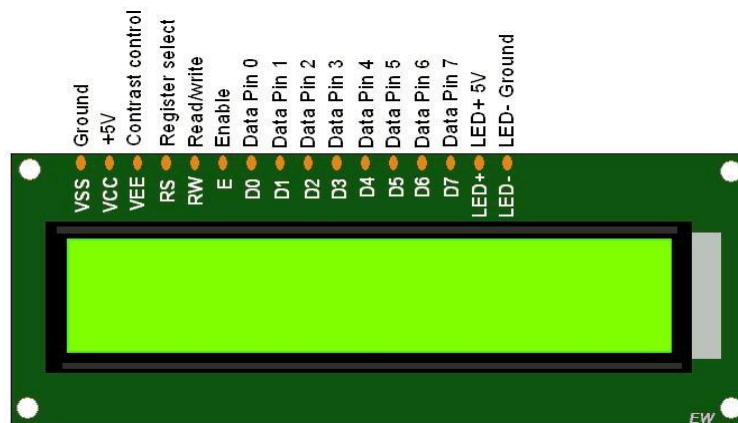

Fig. 2.7 16×2 LCD Display

### 2.8.4.1 FEATURES

- I. 20×4 dots.
- II. Built in control.
- III. +5v supply.
- IV. Backlight LED

### 2.8.4.2 Applications

- I. Monitor to control.
- II. The technology is called liquid crystal.
- III. This is the input that captures digital data and displays it on the output display.
- IV. This is an electrical connection that is dependent on the fluorine device. [7]

### 2.8.5 Resistor

A resistor is a passive electrical element with two terminals that implements electrical resistance as a circuit element. Resistors are used in electronic circuits for reducing current flow, setting signal level, dividing voltages, biasing active elements, and terminating, among other uses, Transmission lines. High energy resistors can be utilized as a component of motor controls or as a test charge for generators, which can dissipate most watts of power as heat. [11]

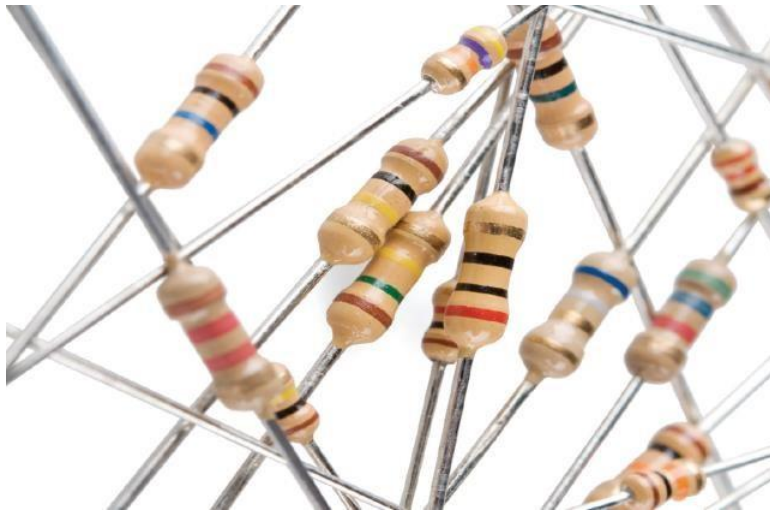
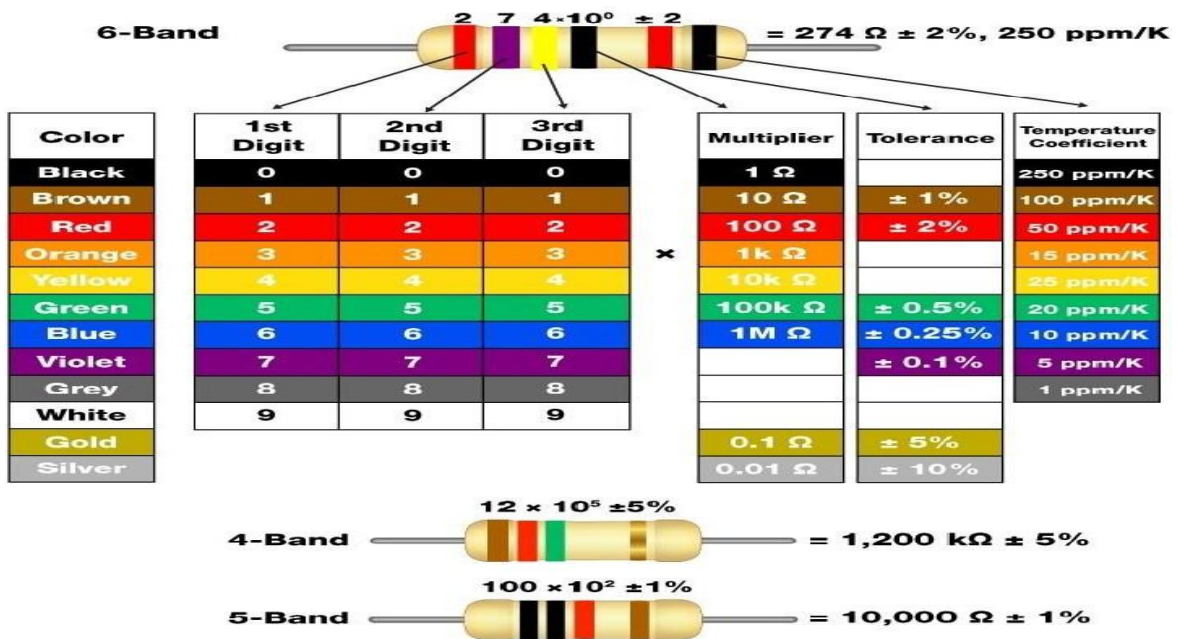

Fig. 2.8 Resistor

### 2.8.5.1 Resistor Color band

Show in the Table of resistor color band

Table 2.2 Resistor color band Table



### 2.8.6 Voltage sensor

The voltage divider is used as a voltage sensor by the voltage divider law. A voltage detector may assess the voltage supply and calculate it. The AC or DC voltage rate can be calculated. Two kinds of capacitive and resistive voltage sensors are usable. Three resistors, capacitor and diode are used in this project for the voltage sensor using divider rule. There are two adjacent resistors and one is in sequence. The Arduino is transmitted to this voltage sensor as 3V=250V.

## 2.8.7 Transformer

An electric transformer is a passive device that transfers electrical power from one or more circuits. You have an alternating electrical source to supply one winding (also called a spiral). A continuously changing, alternating current through the winding generates a flux that surrounds the winding. If another winding comes near this winding, a certain portion of this alternating stream will connect with the second winding. It converts the AC voltage to either rise or fall. Transformer has 220V main windings and secondary winding tapped core. We can use this project 220V to 9V Transformer.



Fig. 2.9 Transformer

### 2.8.7.1 Features of o-9V 300mA Transformer:

- (i) Iron core type.
- (ii) Current gain is 300mA.

### 2.8.7.2 Application of o-9V 300mA Transformer:

- (i) Works as High Current Gain.
- (ii) This transformer basically transfers 220V ac to 0-9V.
- (iii) It has two windings

## 2.8.8 Diode

The diode is a two-terminal electronic element which conducts current mainly in one direction (asymmetric conductivity); it has a small (ideally zero) resistance in one direction and a strong (ideally infinite) resistance in the other. A diode vacuum tube or a thermionic diode is a two-electrode vacuum tube, a heated cathode, and an electron fluid plate, from cathode to plate. [12]

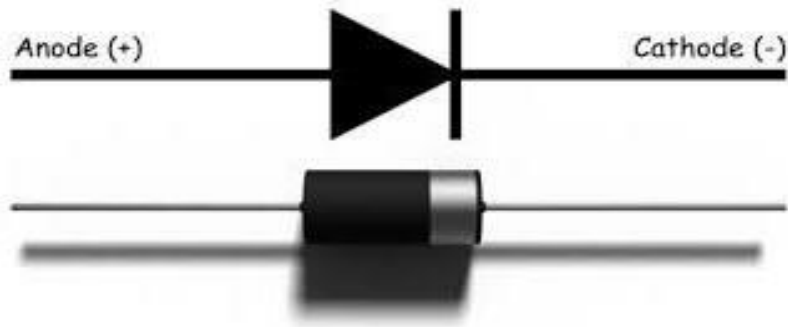

Fig. 2.10 Diode & symbol

### 2.8.9 Capacitor

A capacitor is a device which stores the charge energy known as a passive electronic component in the form of a waveform. The condenser is separated by a dielectric element from two conductive boards. The plates whose extents are specifically corresponding to the surface and are contrarily corresponding to the plates whose plaques. Where the compounds are divided by the dielectric constant. In this project we can use the capacitor for removing pulse. It is used to convert pulse setting DC to Pure DC.



Fig. 2.11 Capacitor

**Symbol:**



Fig. 2.12 Symbol of Capacitor

### 2.8.10 Regulator

The regulation regulator controls voltage and from the law of Ohm we know that when resistance is fixed the voltage is proportional to current. In this project regulating unit, voltage Can be regulated to produce high voltage, low voltage, unbalanced and overload conditions.



Fig. 2.13 Electrical voltage regulator

### 2.8.11 Male Female jumper wire

Wires are used to connect every device. It also connected with every electrical circuit. Wire is a conductor that connects one electric circuit with another or one device with another.



Fig. 2.14 Connecting wire

### 2.8.12 Adaptor

Adaptors are used for converting AC to DC voltage for required value. In this project We can us 220V Ac to 12V Adaptor.



Fig. 2.15 12V DC Adaptor

### 2.8.13 Tools needed



Fig. 2.16 Needed tools

- (i) Solder Iron
- (ii) Solder Roxon
- (iii) Solder Lead
- (iv) Glue-Gun
- (v) Anti-cutter
- (vi) Cutting Plus
- (vii) Digital Multi-Meter
- (viii) Screw Driver
- (ix) Wire Stripper

## **2.9 Summary**

In this chapter we can discuss about all components of the three phase fault detection. We will finish the project by using all these components properly and maintaining the fault. In this chapter we actually discuss in detail the description and the work of each hardware used.

# CHAPTER 3

## METHODOLOGY

### 3.1 Introduction

This chapter describes the methods used to solve algorithms for three phase fault detection. The main topics discussed in this chapter are how this project flow software. Discusses how our project works.

### 3.2 Project Flowchart

In shown as the flowchart diagram,

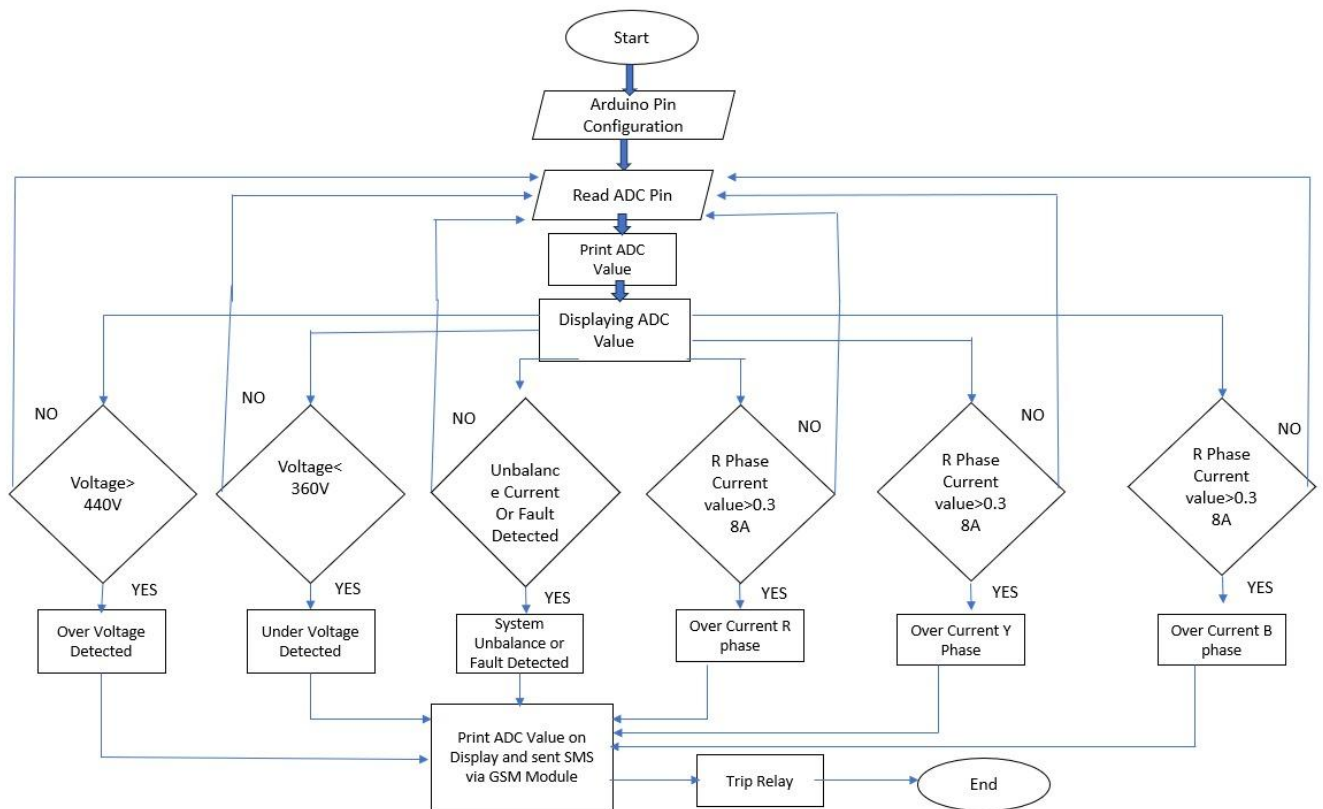

Fig. 3.1 Flowchart of this project

### **3.3 Algorithm of the three phase fault detection device**

Step 1: Start

Step 2: Mode selector condition Yes

Step 3: Generation side

Step 4: Measured the voltage

Step 5: Condition  $\text{Lower voltage} < \text{Set voltage} < \text{Higher voltage}$

Step 6: Arduino Read the value

Step 7: If condition lower voltage

Step 8: Relay condition open and displays lower voltage and alarm

Step 9: If condition higher voltage

Step 10: Relay condition open and displays high voltage and alarm

Step 11: If condition set voltage

Step 12: Relay condition close and display system ok

New step: supply to the load

Step 13: Mode selector condition No

Step 14: Distribution side

Step 15: Measured the current from the current sensor

Step 16: Condition  $\text{phase current difference phase condition} > 15$ ,  $\text{phase condition} < 15$

Step 17: Arduino Read the value

Step 18: If  $\text{phase condition} > 15$

Step 19: Relay condition close and alarming and display unbalance phase

Step 20: If  $\text{phase condition} < 15$

Step 21: Relay condition close and display system ok.

Step 22: Condition If  $I > \text{Set current}$

Step 23: Arduino Read the value

Step 25: Relay condition open and alarming and displays overload

Step 26 If  $I \leq \text{set voltage}$

Step 27: Relay condition close and displays system ok

Step 28: End

### 3.4 Hardware Connection picture

#### GSM Based Three Phase Fault Detection and Protection System

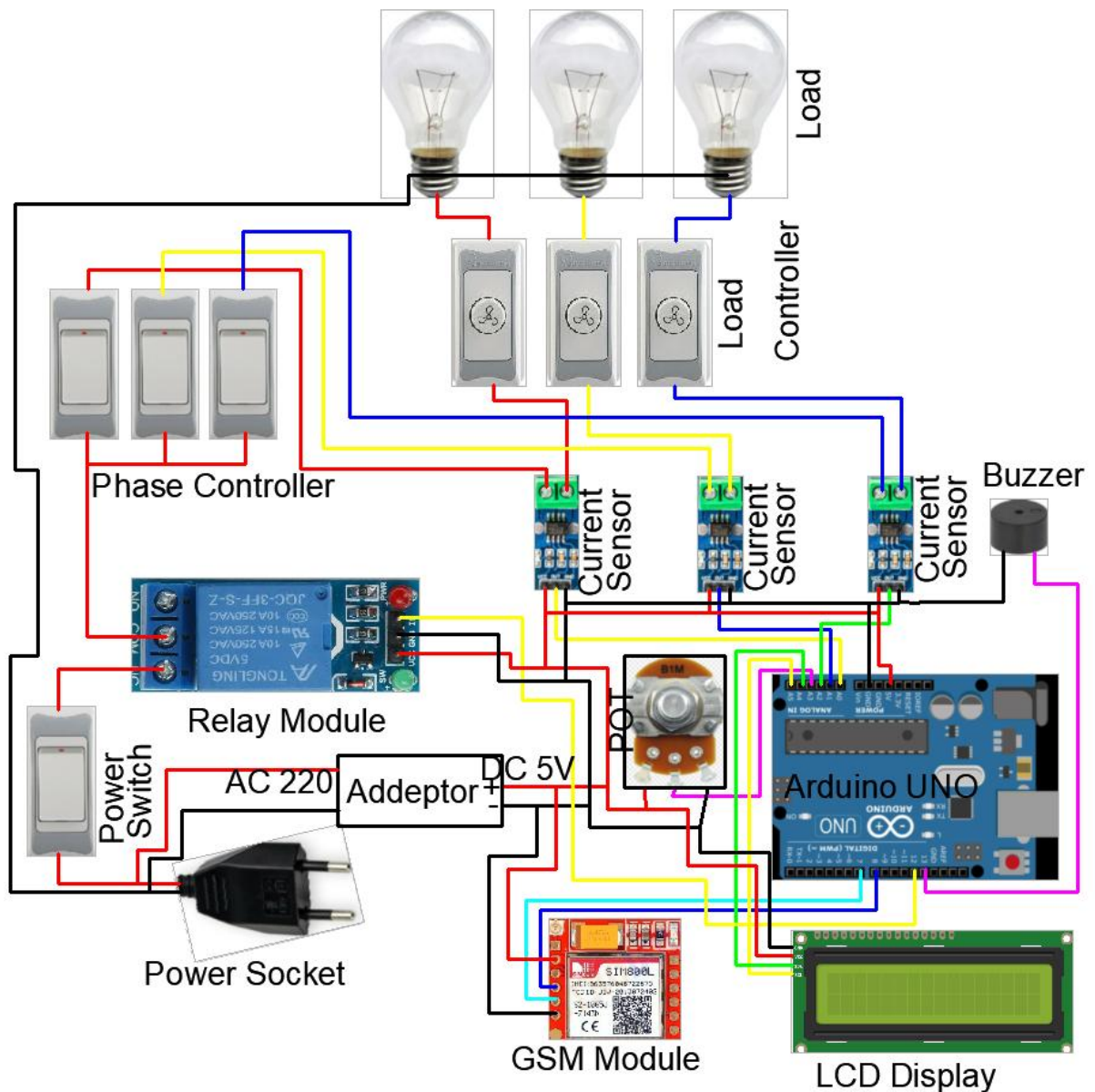

Fig.3.2 Circuit diagram of this project

#### 3.4.1 Description of Hardware Connection

All type of connection of this project Show down:

- ❖ At first AC connection in a Transformer.
- ❖ Transformer converts 220V AC to 9V AC.
- ❖ Transformer 9V AC connecting a rectifier circuit and convert 9V AC to 9V DC.
- ❖ Then 9V DC connected to the Arduino internal power supply panel.
- ❖ Relay, Current sensor, Display driver all ground and VCC are connected to the Arduino ground and VCC pin.

- ❖ Relay in pin connected in AC 220V line.
- ❖ All current sensor series connected Output pin from Relay ON.
- ❖ Current sensor-1 (R) Input is connecting to the Arduino Analog pin A0.
- ❖ Current sensor-2 (Y) Input is connecting to the Arduino Analog pin A1.
- ❖ Current sensor-3 (B) Input is connecting to the Arduino Analog pin A2.
- ❖ Voltage sensor IN pin is connecting to the Arduino Analog pin A3.
- ❖ Displays pin number 1, 5 and 16 are shorted.
- ❖ A 10k variable resistance is connected to displays 1, 2 and 3 no pin.
- ❖ 220 ohms resistance is connected between displays 2 and 15 no pin.
- ❖ Displays pin no 2 is connected to Arduino's 5V pin.
- ❖ Displays pin no 1 is connected to Arduino's GND pin.
- ❖ Displays 4 and 6 no pin is connected to Arduino's digital output pin 7 and 6.
- ❖ Displays D4-D7 pin connected to Arduino's Digital output pin 5-2 respectively.
- ❖ A buzzer is connected between Arduino's digital output pin 11 and GND.
- ❖ A mode switch is connected between Arduino's digital pin 8 and GND.
- ❖ The cable from the current sensor is connected to the dimmer regulator's input cable.
- ❖ For current reduction and loading, the load from dimmer regulator output is connected.

### **3.5 Summary**

The following chapter describes the equipment used during the three phase transmission line fault of this project laze. All the equipment included in this plan is fully designed and operational and should operate well for fault protection. In this chapter we try discussing the details of the hardware characterization used its work.

# CHAPTER 4

## RESULT AND DISCUSSION

### 4.1 Introduction

The main part of the power system is the transmission line. The biggest amount of power transmission lines. The power needs and their allegiance has been dramatically increased during the modern world, with electricity transferred from the source area into the distribution system as the main role of the transmission line. The collision between output limits and massive demands on reducing power failures have increased. Therefore, this project is very helpful for day to day life.

### 4.2 Result

This plan is designed to protect the fault in the transmission line. Defect lines on the transmission line, such as overload, over current flow, short circuit fault, etc. By transforming the analog signal into a digital signal, the amount of current flow that we make through the current sensor in this project is transferred to an Arduino processor. The Arduino processor then completes the process and transmits the high digital signal to the relay. Then the relay connects via the signal to the relay. The Arduino will then give the digital signal to the Display driver, so we can see how amount of current flow through the transmission line. If over current flow through the transmission line then Arduino transferred low signal to the Relay. Arduino transfer a signal through the display, then we can see who fault is organized as like as overload, over current unbalance etc. Arduino and Relay connection is off mode .Relay operate and disconnected the circuit. Then transmission line has no current or no voltage. In the distribution line we therefore find the load on each load. All of this work done through the Arduino program.

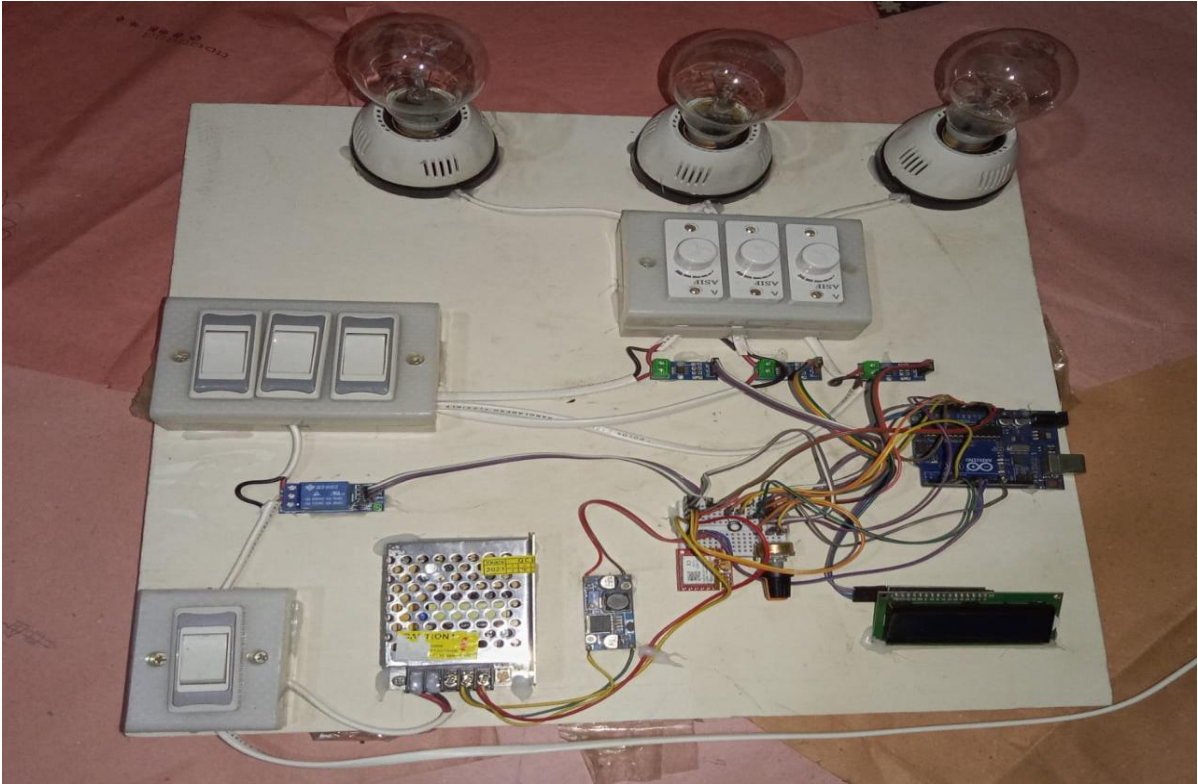

Fig. 4.1 Final project



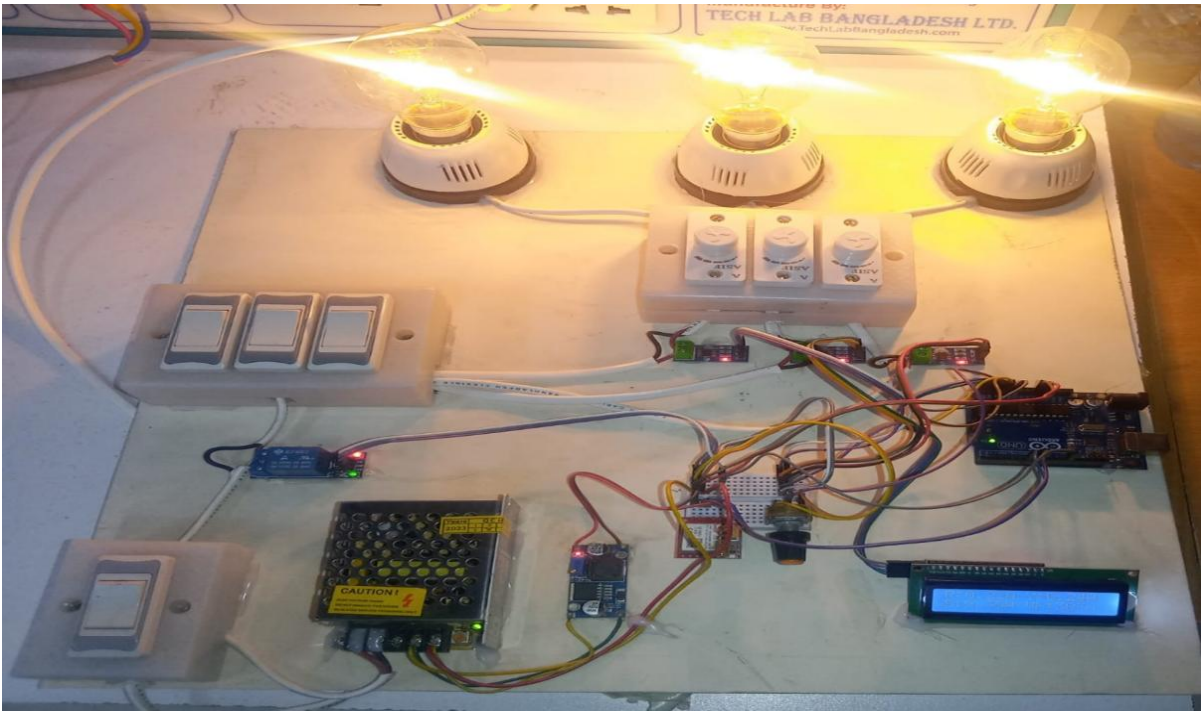

Fig 4.2 Normal condition





Fig 4.3 Fault Condition

### 4.3 Cost Analyses

Table 4.1 Cost analysis of this project

Serial No	Name	Quantity	Price(BDT)
1	Arduino UNO	1	750
2	Current Sensor (ACS712)	3	900
3	Relay Module 5V, 250 V 10A	1	150
4	Display unit 16x2	1	140
5	Buzzer 5V	1	30
6	Diode 4007	1	5
7	Capacitor (1000 $\mu$ F, 470 $\mu$ F)	4	20
8	Resistor (10K,2K,471 $\Omega$ )	3	15
9	Regulator	4	360
10	Board Holder	3	150
11	Transformer(230V-9V, 300mA)	1	80
12	Mode Switch	1	10
13	Switch	2	20
14	Adaptor 12V,1A	1	180
15	Male Female jumper wire		50
16	Board	1	220
17	Others		500
	<b>Total</b>		<b>3580</b>

### 4.4 Advantage of the project

- i. Remove the damage of the transmission line.
- ii. In this project we have create a fault detection transmission line, itdetected fault of the transmission line.
- iii. It's save our transmission and distribution line equipment.
- iv. With the relay in this plan the defective circuit is removed before the system is broken. The Arduino processor recognizes digital signals for all kinds of situations.
- v. It has simple circuit diagram to implement the project.
- vi. Low cost of this project.
- vii. Operation and control is very easy.
- viii. Any kind of fault detected this project and we can see who fault organized in the transmission line.
- ix. Compared with the current system, the coverage area is increasing.
- x. Less part number and manual control. [8]

## **4.5 Summary**

The independent object defect is ready to be executed following completion of all goods pursuant to this chapter. This chapter was mainly challenged by creating an algorithm that works on this transmission line. Thus, the main aim of the chapter was the algorithm and diagram of the conjunction.

# CHAPTER 5

## CONCLUSION

### 5.1 Conclusion

Many voltage and current signal fluctuations are induced by defects of power transmission networks. Stopping the power supply will cause faults in power transmission lines. Thanks to the continuous and precise location information of the device, the time taken to locate the fault is significantly reduced. This means that the skilled crew responds less to repair such faults and thus save transformers from failure and catastrophe. This term enables us to classify the fraud present and process interrupting in the transmission line with the system parameters to be collected and modified. The fault warning software is easily detected and repaired by the line control staff.

### 5.2 Limitation of the project

We realize that the project requires components and that the relay has been rotated to avoid the excess current from passing through the existing detector. Since we have collaborated with the regulator to through the existing through this venture. If we were to use this plan within the borough area, we would be hesitant to use specific signals, substations.

### 5.3 Future Scopes

In this project, a wireless sensor can be used to detect faults that include phase-to-phase, short-circuit and, in particular, ground-to-ground faults in the power line for better reliability and best operation of the system. The proposed power line is divided into WNS (wireless sensor network) nodes that could detect fault in the power line, display to the operator and send SMS through the GSM modem to the service engineer. This idea successfully studies the asymmetrical faults that occur in the power line.

# REFERENCES

- [1] [https://www.ijareeie.com/upload/2017/march/91\\_DISTRIBUTION\\_NC](https://www.ijareeie.com/upload/2017/march/91_DISTRIBUTION_NC) on 19/11/2019
- [2] [https://www.researchgate.net/publication/325708019\\_Transmission\\_Line\\_Fault\\_Detection\\_A\\_Review](https://www.researchgate.net/publication/325708019_Transmission_Line_Fault_Detection_A_Review) on 28/11/2019
- [3] [https://www.globalspec.com/learnmore/sensors\\_transducers\\_detectors/electrical\\_electromagnetic\\_sensing/electrical\\_current\\_sensors](https://www.globalspec.com/learnmore/sensors_transducers_detectors/electrical_electromagnetic_sensing/electrical_current_sensors) on 28/11/2019
- [4] <https://en.wikipedia.org/wiki/Overcurrent>
- [5] <http://engineering.electrical-equipment.org/electrical-distribution/faults-in-electrical-systems-back-to-basics.html> on 11/11/2019
- [6] [https://www.geeetech.com/wiki/index.php/One-Channel\\_Relay\\_module](https://www.geeetech.com/wiki/index.php/One-Channel_Relay_module) on 1/12/2019
- [7] <https://www.elprocus.com/lcd-16x2-pin-configuration-and-its-working> on 1/12/2019
- [8] <https://cdn.instructables.com/pdfs/EF0/KCUS/I9419OLN/Transmission-line-fault-detector-1.pdf> on 04/12/2019
- [9] <https://insights.globalspec.com/article/994/how-electric-current-sensor-technology-works> on 1/12/2019
- [10] <https://www.sciencedirect.com/topics/engineering/overcurrent-protection>
- [11] <https://en.wikipedia.org/wiki/Resistor> on 1/12/2019
- [12] <https://en.wikipedia.org/wiki/Diode> on 1/12/2019
- [13] [https://www.academia.edu/39761083/Automatic\\_Fault\\_Detection\\_and\\_Location\\_of\\_Transmission\\_Lines\\_using\\_IoT](https://www.academia.edu/39761083/Automatic_Fault_Detection_and_Location_of_Transmission_Lines_using_IoT) on 5/12/2019
- [14] <https://ijireeice.com/wp-content/uploads/2018/04/IJIREEICE-19.pdf>
- [15] <https://insights.globalspec.com/article/994/how-electric-current-sensor-technology-works> on 5/12/2019

# APPENDIX

## Code:

### Three phase fault detection of transmission line code as shown:

```
#include <Wire.h> // Include Wire
library for I2C

#include <LiquidCrystal_I2C.h> //
Include LCD library for I2C

#include <SoftwareSerial.h>

// Configure the SIM800L connections

#define SIM800_TX_PIN 7 // Arduino's
digital pin 7 to SIM800L's TX

#define SIM800_RX_PIN 8 // Arduino's
digital pin 8 to SIM800L's RX

SoftwareSerial
sim800(SIM800_TX_PIN,
SIM800_RX_PIN);

const char* phoneNumber =
"+8801305514344";

LiquidCrystal_I2C lcd(0x27, 16, 2); //
Set the LCD address and dimensions

const int sensorPin1 = A0; // Connect
the ACS712 to analog pin A0 for Line 1

const int sensorPin2 = A1; // Connect
the ACS712 to analog pin A1 for Line 2

const int sensorPin3 = A2; // Connect
the ACS712 to analog pin A2 for Line 3

const int sensorPin4 = A3; // Connect
```

*the ACS712 to analog pin A3 for Line voltage*

```
int buzz = 13; // Connect the Buzzer with 13 no pin
```

```
int relay = 12; // Connect the Arduino 13 no pin to relay signal input
```

```
int samples = 1000; // Number of samples for RMS calculation
```

```
void setup() {
```

```
Serial.begin(9600); // Initialize serial communication
```

```
sim800.begin(9600);
```

```
// Setup SIM800L
```

```
delay(2000); // Delay to let the SIM800L module initialize properly
```

```
sim800.println("AT"); // Check if SIM800L is responding
```

```
delay(1000);
```

```
if (sim800.find("OK")) {
```

```
Serial.println("SIM800L is ready");
```

```
} else {
```

```
Serial.println("SIM800L not responding");
```

```
}
```

```
lcd.init(); // Initialize the LCD
```

```
lcd.backlight(); // Turn on the LCD backlight
```

```
pinMode(buzz, OUTPUT);
```

```
pinMode(relay, OUTPUT);
```

```
// Print initial messages on the LCD
```

```

    lcd.setCursor(0, 0);
    lcd.print("3P Fault Protec.");
    lcd.setCursor(0, 1);
    lcd.print("System Ok");
    delay(2000); // Delay for stability
}

```

```

void loop() {
    digitalWrite(buzz,LOW);
    digitalWrite(relay,HIGH);

    int sensorValue4 =
    analogRead(sensorPin4);

    int voltage=
    map(sensorValue4,0,1023,0,460);

    float sum1 = 0, sum2 = 0, sum3 = 0;

    for (int i = 0; i < samples; i++) {
        int sensorValue1 =
        analogRead(sensorPin1);

        int sensorValue2 =
        analogRead(sensorPin2);

        int sensorValue3 =
        analogRead(sensorPin3);

        float voltage1 = (sensorValue1 -
        512.0) / 1024.0 * 5000; // Convert ADC
        value to voltage

        float voltage2 = (sensorValue2 -
        512.0) / 1024.0 * 5000;

        float voltage3 = (sensorValue3 -
        512.0) / 1024.0 * 5000;

        sum1 += voltage1 * voltage1;
        sum2 += voltage2 * voltage2;

```

```

    sum3 += voltage3 * voltage3;
}

float rms1 = ((sqrt(sum1 /
samples))/100)-0.08; // Calculate RMS
for Line 1

float rms2 = ((sqrt(sum2 /
samples))/100)-0.08; // Calculate RMS
for Line 2

float rms3 = ((sqrt(sum3 /
samples))/100)-0.08; // Calculate RMS
for Line 3

if(rms1<0.1){
    rms1=0;
}

if(rms2<0.1){
    rms2=0;
}

if(rms3<0.1){
    rms3=0;
}

if (rms1<0.1 && rms2<0.1 &&
rms3<0.1){

    lcd.clear();

    lcd.setCursor(0, 0);

    lcd.print("System Off");

    lcd.setCursor(0, 1);

    lcd.print("Turn On Switch");

    digitalWrite(relay,LOW);

    delay(10000);
}

```

```
}
```

```
if(rms1>0.38){
```

```
  lcd.clear();
```

```
  lcd.setCursor(0, 0);
```

```
  lcd.print("Over Load R phase");
```

```
  digitalWrite(buzz,HIGH);
```

```
  digitalWrite(relay,LOW);
```

```
  sendSMS("Over Load Detected, R  
phase");
```

```
  delay(10000);
```

```
}
```

```
if(rms2>0.38){
```

```
  lcd.clear();
```

```
  lcd.setCursor(0, 0);
```

```
  lcd.print("Over Load Y phase");
```

```
  digitalWrite(buzz,HIGH);
```

```
  digitalWrite(relay,LOW);
```

```
  sendSMS("Over Load Detected, Y  
phase");
```

```
  delay(10000);
```

```
}
```

```
if(rms3>0.38){
```

```
  lcd.clear();
```

```
  lcd.setCursor(0, 0);
```

```
  lcd.print("Over Load B phase");
```

```
  digitalWrite(buzz,HIGH);
```

```

    digitalWrite(relay,LOW);

    sendSMS("Over Load Detected, B
phase");

    delay(10000);
}

```

```

if(((rms1-rms2)>=0.15 || (rms2-
rms3)>=0.15 || (rms3-
rms1)>=0.15||(rms2-rms1)>=0.15 ||
(rms3-rms2)>=0.15 || (rms1-
rms3)>=0.15)&& rms1>0 &&
rms2>0&& rms3>0){

```

```

    lcd.clear();

```

```

    lcd.setCursor(0, 0);

```

```

    lcd.print("System Unbalance");

```

```

        digitalWrite(buzz,HIGH);

```

```

        digitalWrite(relay,LOW);

```

```

        sendSMS("System Unbalance");

```

```

        delay(10000);

```

```

}

```

```

if(rms1==0 && rms2>=0 && rms3>=
0){

```

```

    lcd.clear();

```

```

    lcd.setCursor(0, 0);

```

```

    lcd.print("R phase Missing");

```

```

        digitalWrite(buzz,HIGH);

```

```

        digitalWrite(relay,LOW);

```

```

        sendSMS("Phase Fail detected, R
Phase Missing");

```

```

        delay(10000);

```

```

}

```

```

if(rms1>=0 && rms2==0 && rms3>=
0){
    lcd.clear();
    lcd.setCursor(0, 0);
    lcd.print("Y phase Missing");
        digitalWrite(buzz,HIGH);
        digitalWrite(relay,LOW);
        sendSMS("Phase Fail detected, Y
Phase Missing");
        delay(10000);
}

```

```

if(rms1>=0 && rms2>=0 && rms3==
0){
    lcd.clear();
    lcd.setCursor(0, 0);
    lcd.print("B phase Missing");
        digitalWrite(buzz,HIGH);
        digitalWrite(relay,LOW);
        sendSMS("Phase Fail detected, B
Phase Missing");
        delay(10000);
}

```

```

if (voltage>440){
    lcd.clear();
    lcd.setCursor(0, 0);
    lcd.print("Over Voltage Dt.");
        digitalWrite(buzz,HIGH);
        digitalWrite(relay,LOW);
        sendSMS("Over Voltage Detected ");
        delay(10000);
}

```

```
}
```

```
if (voltage<340){
```

```
    lcd.clear();
```

```
    lcd.setCursor(0, 0);
```

```
    lcd.print("Under Voltage Dt.");
```

```
        digitalWrite(buzz,HIGH);
```

```
        digitalWrite(relay,LOW);
```

```
        sendSMS("Under Voltage Detected  
");
```

```
        delay(10000);
```

```
}
```

```
lcd.clear();
```

```
lcd.setCursor(0, 0);
```

```
lcd.print("R:");
```

```
lcd.print(rms1);
```

```
lcd.print("A");
```

```
lcd.setCursor(8, 0);
```

```
lcd.print("Y:");
```

```
lcd.print(rms2);
```

```
lcd.print("A");
```

```
lcd.setCursor(0, 1);
```

```
lcd.print("B:");
```

```
lcd.print(rms3);
```

```
lcd.print("A");
```

```
lcd.setCursor(8, 1);
```

```
lcd.print("VL:");
```

```

    lcd.print(voltage);
    lcd.print("v");

    delay(500);
}

void sendSMS(const char* message) {
    Serial.println("Sending SMS...");

    sim800.println("AT+CMGF=1"); //
    Set SMS mode to text

    delay(1000);

    sim800.print("AT+CMGS=\""); //
    Command to send SMS to a specific
    phone number

    sim800.print(phoneNumber);

    sim800.println("\"");

    delay(1000);

    sim800.print(message); // Message you
    want to send

    delay(100);

    sim800.write(26); // Equivalent to
    sending Ctrl+Z to end the SMS message

    delay(1000);
}

```